

# DST-2000C

## *Direction Sensing Tachometer*

### INSTRUCTION MANUAL



Azonix-Dynalco, 3690 N. W. 53 Street, Ft. Lauderdale, FL 33309 U.S.A.

☎ (954) 739-4300 • Fax (954) 484-3376

[www.dynalco.com](http://www.dynalco.com) • [mailbox@dynalco.com](mailto:mailbox@dynalco.com)

**October 1999**

This document contains information on a new product. Specifications and information herein are subject to change without notice. Dynalco Controls reserves the right to make changes to the equipment described herein to improve function or design. Although the information contained in this manual has been carefully reviewed and is believed to be reliable, Dynalco Controls does not assume any liability arising out of the application or use of the equipment described herein. Warranty is limited and cannot exceed the price paid for the product upon which the warranty is based.

DST-2000C and M343, DST-2000B, and M917 are trademarks of Dynalco Controls.

© 1999 Dynalco Controls

All rights reserved  
Printed in U.S.A.

# Table of Contents

---

<b>Overview .....</b>	<b>5</b>
<b>1 Product Description.....</b>	<b>5</b>
1.1 Features .....	5
1.2 Functional Description.....	5
1.3 Terminal Connections and Dimensions.....	6
Figure 1-1 Outline Drawing .....	5
1.4 Specifications .....	6
1.5 Minimum Speed Requirements .....	6
Table 1-1 Minimum RPM with Gear .....	6
1.6 Tach Tape (TT-100) .....	6
Table 1-2 Minimum RPM with TT-100.....	6
<b>2 Installation .....</b>	<b>8</b>
2.1 Tools and Hardware .....	8
2.2 DST-2000C Terminals.....	8
2.3 Wiring Connections Between DST-2000C and M343 Connector.....	9
2.4 Calibration Procedure.....	9
2.4.1 Required Equipment.....	9
2.4.2 Connections .....	9
2.4.3 Calibration .....	10

**BLANK PAGE**

# DST-2000C INSTRUCTION MANUAL

---

## Overview

The purpose of this manual is to provide the users with the information necessary to install and operate the DST-2000C™ Direction Sensing Tachometer.

## 1 Product Description

The DST-2000C operates with the M343 dual output magnetic pickup to detect the direction of rotation, and provides outputs to indicate direction and speed. (The older M917 pickup is no longer manufactured. This pickup ONLY works with the DST-2000B.)

### 1.1 Features

- Provides two SPDT relay outputs, one energizes on CW rotation, the other on CCW rotation.
- Provides two 10 mA drive current outputs to illuminate customer-provided LED indicators, one for CW rotation, the other for CCW rotation.
- Provides two pulsed outputs, one for CW rotation, the other for CCW rotation, that can serve as an input signal to Dynalco tachometer DS-800.
- Provides a 0–1 mA output proportional to speed that can serve as input signal to Dynalco tachometer models G-101 or DPM-105.
- Provides an amplified square wave output signal equal to the input frequency to serve as input signal for Dynalco models SPD-100, SPD-700, LST-100, and DS-800.
- Provides a regulated 8 Vdc (25 mA) auxiliary output to power Dynalco digital panel meter DPM-105.

### 1.2 Functional Description

The DST-2000C receives two input signals from the Dynalco M343 dual output magnetic pickup. The circuits within the DST-2000C evaluate the two input signals and activate the appropriate relay (CW or CCW) to indicate direction of rotation.

The DST-2000C outputs a proportional 0–1 mA analog signal as well as a buffered square wave (8 V peak-to-peak) equal to the input frequency. The DST-2000C also outputs a 10 mA signal to drive external LEDs which indicate the direction of rotation (CW and CCW). There are also two pulse outputs, one for CW, the other for CCW.

There is one pulse per discontinuity. Pulses are 0 to +8 Vdc, 35 microsecond nominal width.

To avoid false indications at near zero speed, the active relay indicating direction will remain activated for 2 seconds with no signal input. It will then automatically reset.

### 1.3 Terminal Connections and Dimensions

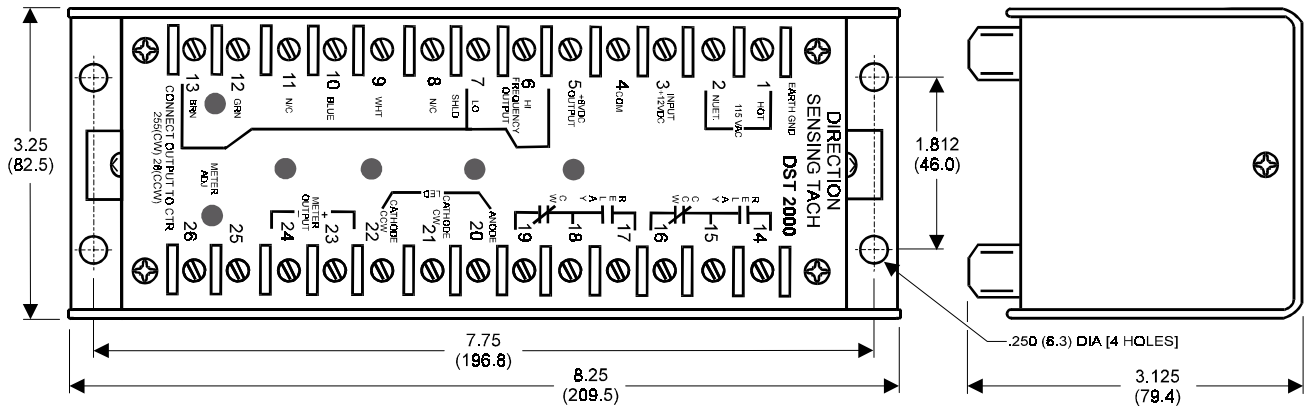

Figure 1-1 Outline Drawing

### 1.4 Specifications

Input Signal:	Signal from Dynalco M343 dual output magnetic pickup only. Frequency range 0.5 Hz to 20 kHz.
Signal Amplitude:	25 mVrms minimum; 15 Vrms maximum.
Input Power:	115 Vac and/or 12 Vdc (standard)* 115 Vac and/or 24 Vdc (optional)* 230 Vac and/or 12 Vdc (optional)* 230 Vac and/or 24 Vdc (optional)* *±10%, 50/60 Hz, ±10%, 2 watts maximum
Input Current:	2 watts, maximum.
Operating Temperature:	-30°F to +160°F (-34°C to +71°C)
Output Relays:	Two SPDT relays. Contact rated 5 A, resistive, 115 Vac.
Remote LED Outputs:	Two 10 mA nominal outputs.
Directional Output Pulses:	Two outputs: one for CW, one for CCW. Pulses are 0 to +8 V, 35 microseconds nominal width.
Speed Signal Output:	Proportional to input frequency. Square wave 8 V peak-to-peak.
Meter Output:	0–1 mA analog output proportional to input frequency.
Auxiliary Output Supply:	Regulated +8 Vdc (25mA).

## 1.5 Minimum Speed Requirements

At very low speeds, the amplitude of the output signal from the M343 will be below the sensitivity level of the DST-2000C. At these low speeds the DST-2000C will not be able to detect direction of rotation. The output amplitude of the M343 is affected by the diameter of the gear being sensed and by the air gap between the gear and the M343. Table 1-1 shows the minimum speed required (in RPM) for the DST-2000C to detect rotation for a variety of gear diameters at various air gaps.

<b>Gear Dia. in Inches</b>	<b>0.005 in. gap</b>	<b>0.010 in. gap</b>	<b>0.015 in. gap</b>	<b>0.020 in. gap</b>	<b>0.030 in. gap</b>	<b>0.040 in. gap</b>
<b>4</b>	16	27	40	54	89	160
<b>6</b>	11	18	27	36	59	107
<b>8</b>	8	14	20	27	45	80
<b>10</b>	7	11	16	22	36	64
<b>12</b>	6	9	14	18	30	54
<b>14</b>	5	8	12	16	26	46
<b>16</b>	4	7	10	14	23	40
<b>18</b>	4	6	9	12	20	36
<b>20</b>	4	6	8	11	18	32
<b>22</b>	3	5	8	10	17	29
<b>24</b>	3	5	7	9	15	27
<b>30</b>	3	4	6	8	12	22
<b>36</b>	2	3	5	6	10	18

**Table 1-1 Minimum RPM with Gear**

## 1.6 Tach Tape (TT-100)

When using Tach Tape (TT-100) on a shaft, the minimum speeds will be different than with a gear. Table 1-2 shows the minimum speed required to detect rotation for a variety of shaft diameters at various air gaps when using TT-100.

<b>Shaft Dia. in Inches</b>	<b>0.005 in. gap</b>	<b>0.010 in. gap</b>	<b>0.015 in. gap</b>	<b>0.020 in. gap</b>	<b>0.003 in. gap</b>	<b>0.040 in. gap</b>
<b>4</b>	51	68	84	96	127	192
<b>6</b>	35	45	56	64	85	129
<b>8</b>	26	34	43	48	64	97
<b>10</b>	21	28	34	39	51	77
<b>12</b>	18	23	29	32	43	65
<b>14</b>	16	20	25	28	37	55
<b>16</b>	14	18	22	25	32	49
<b>18</b>	13	16	19	22	29	43
<b>20</b>	12	15	18	20	26	39
<b>22</b>	11	13	16	18	24	35
<b>24</b>	10	12	15	17	22	33
<b>30</b>	8	10	12	14	18	26
<b>36</b>	7	9	10	11	15	22

**Table 1-2 Minimum RPM with TT-100**

## 2 Installation

The DST-2000C is supplied in an industrial, painted steel housing which is designed to be installed within an enclosure. The DST-2000C can be mounted horizontally or vertically depending on the specific application conditions. A space of 6¼ X 11¼ inches allows for a minimum 1½ inches of clearance for ease of access needed for terminal connections and servicing. The system installation should comply with all appropriate electrical codes and standards.

### 2.1 Tools and Hardware

#### Required Tools

Screwdriver  
Drill  
#21 drill bit  
10-32 tap

#### Required Hardware

Four (4) 10-32 screws  
Four (4) #10 lock washers

### 2.2 DST-2000C Terminals

Terminal	Connect To
1	115 Vac (Hot) input or 220 Vac, optional
2	115 Vac (neutral) input or 220 Vac, optional
3	+12 Vdc input or +24 Vdc, optional
4	-12 Vdc (Common) input or -24 Vdc, optional
5	Regulated + 8 Vdc output
6	Square wave frequency output (Hi)
7	Square wave frequency output (Lo)
8	No connection
9	Input from M343 ( <i>White lead from C917-10</i> )
10	Input from M343 ( <i>Blue lead from C917-10</i> )
11	No connection
12	Input from M343 ( <i>Green lead from C917-10</i> )
13	Input from M343 ( <i>Brown lead from C917-10</i> )
14	CCW Relay NO contact output
15	CCW Relay Common output
16	CCW Relay NC contact output
17	CW Relay NO contact output
18	CW Relay Common output
19	CW Relay NC contact output
20	Anode for external LED output
21	Cathode for CW LED output (10 mA)
22	Cathode for CCW LED output (10 mA)
23	0-1 mA meter output (+)
24	0-1 mA meter output (-)
25	CW +8 V, 35 microsecond, pulse output
26	CCW +8 V, 35 microsecond, pulse output



## 2.3 Wiring Connections Between DST-2000C & M343 Pickup Connector

Wiring connections between the DST-2000C and the M343 magnetic pickup connector C917-X (X = length of connector cable in inches) are as follows:

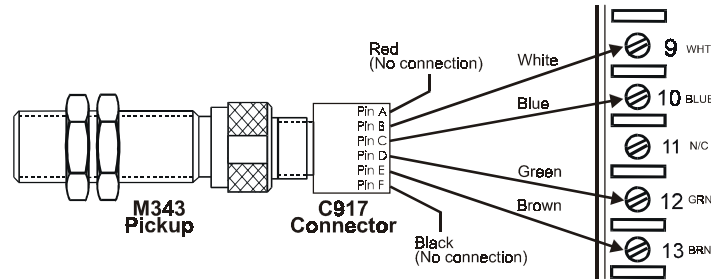

## 2.4 Calibration Procedure

The only calibration to the DST-2000C recommended by the factory is calibration of the 0–1 mA Meter Output. {Note: The two potentiometers on the bottom of the PC board are factory adjustments *only* and no user adjustment should attempted.}

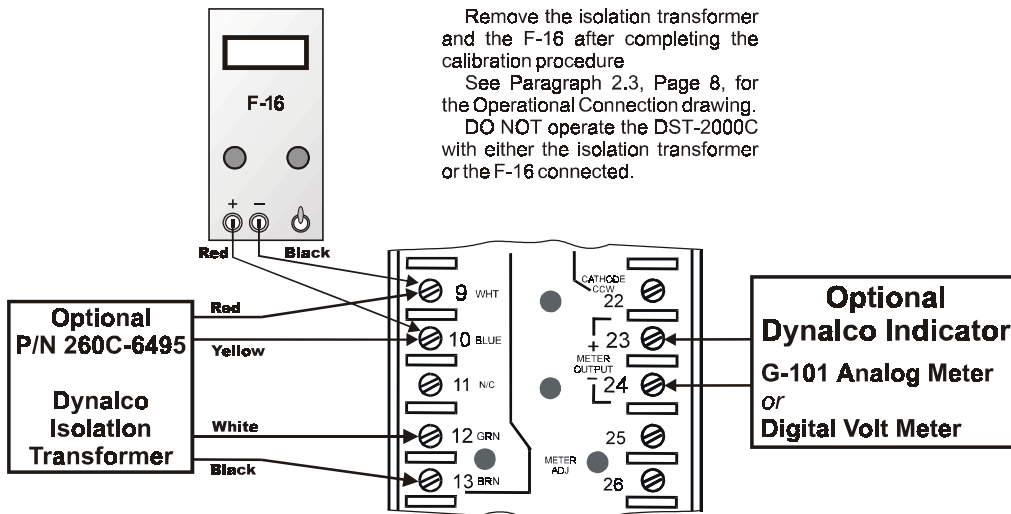

### 2.4.1 Required Equipment

- Dynalco F-16 Frequency Generator or similar *square wave* generator
- Dynalco G-101 meter or digital voltmeter
- Dynalco isolation transformer p/n 260C-6495

### 2.4.2 Connections

- Connect the G-101 to the meter output terminals of the DST-2000C: terminals 23 (+) and 24 (-).
- Connect the F-16 signal generator to the DST-2000C terminals 9 (+) and 10 (-).
- Connect the red lead of the 260C-6495 transformer to terminal 9 of the DST-2000C and the yellow lead to terminal 10.
- Connect the white lead of the 260C-6495 transformer to terminal 12 and the black lead to terminal 13 of the DST-2000C.

### 2.4.3 Calibration

- Turn the F-16 power on and verify the Count/Generate switch is in the Generate position.
- Adjust the F-16 to the full-scale frequency as required by the application. To compute the full-scale frequency, multiply (the number of discontinuities sensed) by (the maximum speed) and divide by 60.

$$\text{Hertz (frequency)} = \text{Number of Gear Teeth} \times \text{RPM} \text{ divided by } 60$$

- Connect power source to DST-200C
- Turn power on to the DST-2000C.
- Verify that the CW relay energizes.
- Adjust the meter output potentiometer to obtain full-scale deflection on the G-101 or 5 Vdc on digital voltmeter.
- Reverse the connections of the white and black leads of the transformer and verify the CCW relay energizes and the CW relay de-energizes.
- Turn the F-16 power off and verify that the CCW relay de-energizes after approximately 2 seconds.

**BLANK PAGE**

