



# Gas Engine Solutions

**WOODWARD**  
E<sup>3</sup> Rich-Burn Control with StableSense  
Air-Fuel Ratio Controls and Governors

**DCL**  
Catalysts and Monitors

**Basler Electric**  
Voltage Regulators

**GCS**  
HMI & SCADA Systems

**TDI**  
TECH DEVELOPMENT INC.  
Air Starters

**SPINNER II PRODUCTS**  
Mfr. by Mann Hummel  
Oil Cleaning Centrifuges

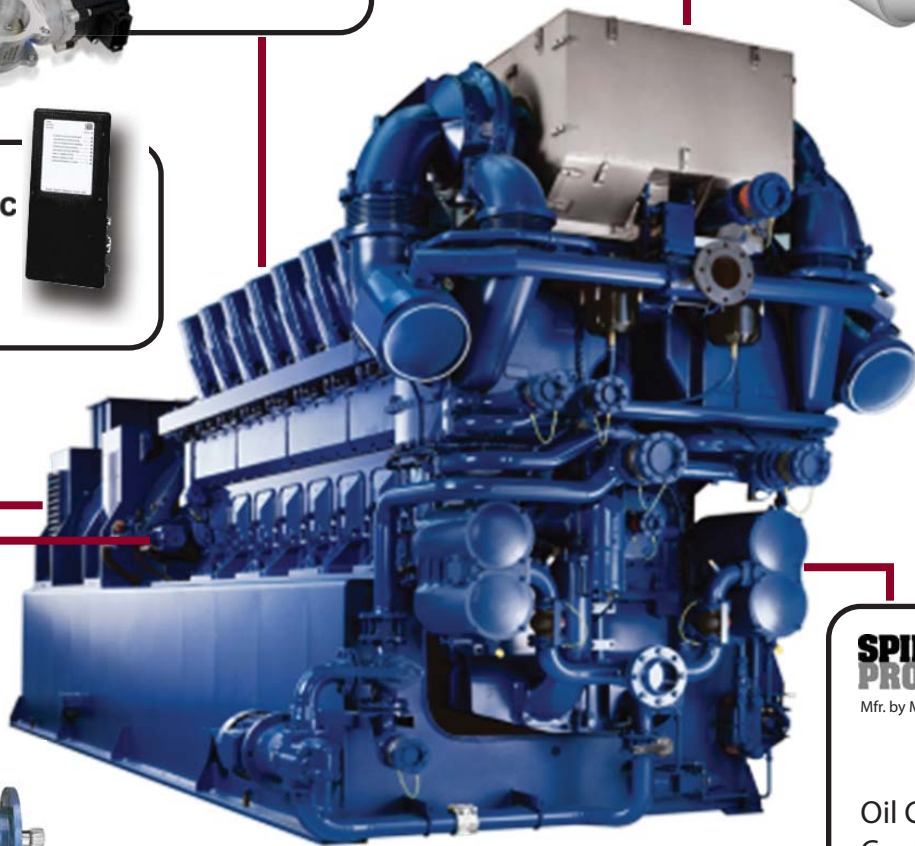

## Innovative solutions for your engines.

Representing leading manufacturers of gas engine controls, monitors, regulators and starters, **Governor Control Systems, Inc. (GCS)** designs and installs systems that:

- Reduce Emissions
- Improve Performance
- Consistent Startups
- Maximize Fuel Economy

## Maintaining consistent performance

Reliable air-fuel ratio control, sensors, digital ignition system and an oxidation catalyst/silencer are critical items for maintaining **engine control and emissions compliance.**

## Governor Control Systems, Inc.

Florida: 877-659-6328 Gulf Coast: 888-427-4853 Mid-Atlantic: 877-659-6328 Pacific Northwest: 206-297-0300  
www.govconsys.com

Innovative energy control and optimization solutions for industrial engines and electrical power equipment to maximize energy efficiency, reliability and quality, fuel flexibility, and reduce emissions. Woodward Engine Management Solutions address the strict EPA emissions regulations while providing advanced generator controls, load sharing, synchronization and power protection technologies.

**E3 Gas Engine Control System:** This fully-integrated approach permits precise governing and air-fuel ratio control while remaining flexible enough for large variations in fuel quality. The system is designed to control industrial gas engines used in numerous power generation, pumping, and other stationary applications ranging from 300 kW to 2000 kW (400–2700 hp). Scalable, full authority over spark, fuel, and air; integrated misfire diagnostics.



**WoodwardE3 Engine/Emissions Controls**

Allows gas engines to maintain peak efficiency with varying fuel quality



**DCL oxidation catalysts**, three-way catalysts, and SCR systems are the industry standard for rugged, reliable emissions controls. DCL QUICK-LID® and MINE-X® catalytic converters effectively reduce engine exhaust emissions, including NOx, CO, hydrocarbons, formaldehydes and particulates. With DCL's Siloxane Removal Technology, engines experience reduced downtime and need less maintenance and repair.

**QUICK-LID® & MINE-X®**  
Catalytic Converters & Silencers



**Siloxane Removal Technology**

Advanced gas pre-treatment and purification system to remove harmful siloxanes from the gas supply.



**Data Collection & Reporting**

HMI and SCADA systems provide a window into the complete system by displaying current/historical information and alarm handling. Personnel can view a series of screens and remotely monitor their control systems.

**Continuous Parameter Monitoring System (CPMS)**

monitors the inlet temperature and differential pressure of the catalyst, as required by EPA regulations.



**Spinner II Oil Cleaning Centrifuges** remove the most damaging by-products of the combustion process using centrifugal force to spin contaminants out of your oil – including soot and other particles as small as one-tenth of a micron. Removes large particles to prevent catastrophic engine failure; remove small particles to reduce engine wear.



**TDI Air Starters** are designed for ultimate reliability, durability and long life. The compact design, fewer moving parts, pinion gear, and mechanical integration of each component are what deliver true TurboTwin performance.





# GCS engineers systems that help bring your engines into compliance while enhancing the operation and performance of the engine.

## Woodward E3 Air-Fuel Ratio Control and Actuation System retrofits Caterpillar G3516LE lean burn gas engine-generators at a landfill facility power generation plant.



### Meeting RICE-NESHAP Emissions Regulations

The primary reason for the upgrade was to meet RICE NESHAP emissions regulations – E3 system compensates for changes in fuel quality while maintaining the proper emissions.

### Inconsistent Starting

The added benefit has been improved, consistent engine starting. Prior to installing the new E3 control system, operators had to manually throttle the fuel back and nurse the fuel to the engines until they started. The process was inconsistent from one start to the next due to variable quality landfill gas. The new E3 control systems operate the Woodward fuel valves to automatically control the inlet fuel to the engines, providing the correct amount of fuel for starting - everytime.



## Protecting Landfill Gas Engines: Spinner II Centrifuge Dramatically Increases Run Times

### Removing contaminants in landfill gas engines

Oil change frequencies for biogas engines are much shorter than those for natural gas engines, due to contaminants in biogas and the high load factors on the engines. On engines equipped with catalytic converters, standard lube oil or lube oil residue may damage the catalyst. The solution is more costly, specially blended oil. Maintaining clean oil and extending drain intervals has a great impact on productivity and cost-efficiency.

### Increasing Oil and Filter Life

In a landfill operating a large scale waste-to-energy project using Jenbacher J320 Landfill Gas Engines, the gas collected contained high percentages of impurities. The engines ran only 400 hours before total acid number (TAN) rose and total base number (TBN) dropped to unacceptable levels. Attempts to control acid levels resulted in increased levels of silica and high wear rates. Spinner II Oil Cleaning Centrifuges were installed, processing up to 30 L/min (8 gpm), cleaning a sidestream of oil and returning it to the sump. The life of the oil and filters were increased by approximately 75%.



**SPINNER II PRODUCTS**  
Mfr. by Mann Hummel



## Three-Way Catalysts for Gas Compressor



### Emissions Control System

- Natural gas compressor station, powered by Waukesha engines.
- The challenge was to meet emission targets for NO<sub>x</sub>, CO and non-methane hydrocarbons, for various compressor engines with different exhaust configurations.

### Solution:

The catalyst housings were supplied in two basic configurations for this project. The first configuration was a separate catalyst housing and muffler. The second configuration was a combined catalyst housing and muffler in one unit. All the catalyst elements were arranged in the DCL QUICK-LID®, which allows the catalyst elements to be easily removed for servicing.



## Dual-Fuel Engines - An Old Concept with a New Following

With the prices of diesel fuel rising and increasing regulation on emissions, many operators are searching for an alternative to conventional fuel. Dual-fuel systems incorporate electronic controls that enhance system performance, representing a viable alternative for diesel engines.

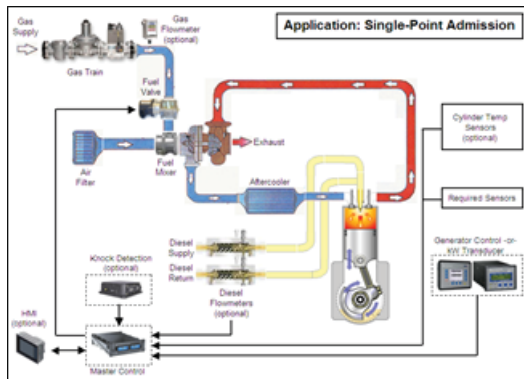

**Single-Point Admission (High speed engines)**  
The control system utilizes a series of sensors and transducers to calculate the optimum diesel-to-gas ratio and position the fuel valve(s).

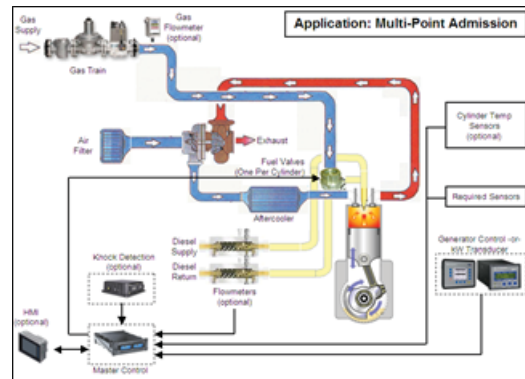

**Multi-Point Admission (Low speed engines)**  
An electronic control drives the individual fuel solenoid valves controlling timing and duration of fuel injection into the cylinder.

### Benefits of Dual-Fuel Operation

- Reduce diesel fuel storage and usage
- Extend life of existing diesel supply
- Eliminate costly spark plug maintenance
- Natural gas is environmentally cleaner than diesel fuel
- Retrofit systems are quickly installed, minimizing engine downtime
- Engine maintenance intervals and engine life are extended



## Reducing the Cost of Compliance

Serving you from three strategic locations, GCS offers cost-effective, innovative solutions to meet your needs for:

- Emission controls
- Improved engine performance
- Reliability and efficiency

Our applications engineers have experience applying control and emissions monitoring systems on hundreds of engines. We guide you in specifying and installing the correct equipment to meet your engine operating conditions.

GCS offers comprehensive control and monitoring solutions, from engine and turbine systems integration to turnkey project management. We support a broad range of marine, power generation and industrial projects.

To discuss your compliance requirements, contact GCS toll free at **877-659-6328** or **888-427-4853** or email [contact@govconsys.com](mailto:contact@govconsys.com).

Visit [www.govconsys.com](http://www.govconsys.com) for a complete list of all our products and services.



## RICE NESHAP Compliance

**RICE NESHAP** is the acronym for the United States EPA rule:

### Reciprocating Internal Combustion Engines National Emissions Standards for Hazardous Air Particles.

The standards apply to emissions of NO<sub>x</sub>, PM, CO, and NMHC. These **RICE NESHAP** rules are applicable to existing diesel and spark-ignited engines.

**May 3, 2013** for existing Compression Ignition engines (diesel engines)

**October 19, 2013** for existing Spark Ignited engines (gas engines)

The EPA provides a navigation tool to help owners and operators of reciprocating internal combustion engines determine their requirements: [www.epa.gov/ttn/atw/rice/output/quiz.html](http://www.epa.gov/ttn/atw/rice/output/quiz.html).

For complete details regarding 40 CFR, Part 63, Subpart ZZZZ, refer to EPA site: [www.epa.gov/ttn/atw/rice/ricepg.html](http://www.epa.gov/ttn/atw/rice/ricepg.html).

GCS is part of the MSHS Group, providing turn-key solutions for prime movers.

#### Southeast

3101 SW 3rd Avenue  
Ft. Lauderdale, FL 33315  
Phone: 954-462-7404  
Toll Free: 877-659-6328  
Fax: 954-761-8768

#### Gulf Coast

2022 Tamvest Court  
Mandeville, LA 70448  
Phone: 985-626-8707  
Toll Free: 888-GCS-GULF  
Fax: 985-626-8732

#### Mid-Atlantic

3120 Arizona Avenue  
Norfolk, VA 23513  
Phone: 757-852-5808  
Toll Free: 877-659-6328  
Fax: 757-852-5809

#### Pacific Northwest

3426 17th Avenue West  
Seattle, WA 98107  
Phone: 206-297-0300  
Fax: 206-297-0302



[www.govconsys.com](http://www.govconsys.com)