



## DSLC-2™ Digital Synchronizer and Load Control

### DESCRIPTION

Woodward blended the original solid DSLC™ with another decade of application experiences in developing the new DSLC-2™. The DSLC-2™ excels in either simple generator or complex generator system applications. The DSLC-2™/MSLC-2™ combination provides multiple unit, segment, utility and intertie breaker control for complex power systems.

The Woodward DSLC-2™ control is a microprocessor-based synchronizer and load control designed for use on three-phase AC generators. The DSLC-2™ control combines synchronizer, load sensor, load control, dead bus closing system, VAR, power factor and process control, all integrated into one powerful package. Applications allow up to 32 generators to be precisely paralleled and controlled. A dedicated Ethernet system provides seamless communications between DSLC-2™ and MSLC-2™ units. A second Ethernet port is provided for customer remote control and monitoring capability using Modbus TCP allowing easy DCS and PLC interfacing. Modbus RTU is available through a separate RS-485 port.

Slip frequency or phase matching automatic synchronizing with or without dead bus closing is selectable.

The DSLC-2™ control senses true RMS power and provides soft bump-less loading and unloading functions. It can either base load or set import/export/process power levels against the utility, or accurately share loads on isolated, multiple generator systems.

VAR and power factor control flexibility allows you to either provide a set level of VARs to the utility or to maintain a constant power factor for reliable operation. The VAR/PF control also shares kVARs in an isolated systems, maintaining proportional reactive loads (kVARs) on all machines more accurately than droop or cross-current voltage systems.

### FEATURES

- Dedicated Ethernet line for precise system communications between all DSLC-2's™ and MSLC-2's™ significantly reduces system wiring.
- Ethernet Modbus TCP for remote control and monitoring.
- Flexible hardware allows the new DSLC-2™ to be used in different applications which previously would have required one of 12 separate DSLC™ part numbers.
- Integrated DSLC-2™ and MSLC-2™ system functionality eliminates the need for redundant sensors (like PTs, CTs, and MOPs) that connect to individual modules such as the load sensors and synchronizers.
- Back panel mounting and a reduced size frees up door space and provides easy wiring.
- Eliminates the need for additional relay logic to control dead bus closing.
- Slip frequency paralleling, voltage matching, and speed bias transfer between the synchronizer and load control result in smooth paralleling without the risk of reverse power trips.
- Three-phase true RMS power sensing makes the DSLC-2™ control accurate even with unbalanced phase loading and voltage fluctuations.
- The Woodward ToolKit™ software allows flexible setup using the same basic menu tree as the original DSLC™ plus an overview screen. No hand held programmer is required. Graphical overview of generator and bus bar parameters with trending makes the DSLC-2™ commissioning friendly.

- Applications for up to 32 generators using 32 DSLC-2™ and up to 16 MSLC-2™ controls.
- Complex applications with up to 8 bus segments
- Four communication ports
- Ethernet A port for unit to unit communications
- Ethernet B port for remote control monitoring via Modbus TCP
- RS-485 port for remote control via Modbus RTU
- RS-232 port for configuration of device using Woodward ToolKit software
- Automatic generator soft loading and unloading for bump-less load transfer
- Isochronous load sharing with other DSLC-2™ equipped sets
- Process control
- VAR or Power Factor control
- Dead bus closing
- PLC & DCS compatible
- One part number is adjustable for multiple speed controls, voltage regulators, and potential transformer configurations
- Application range up to 999 MW
- Not compatible with original DSLC™
- UL/cUL & CE Listed

# SPECIFICATIONS

Power supply	12/24 Vdc (8 to 40 Vdc)
Intrinsic consumption	max. 15 W
Ambient temperature (operation)	-40°C to 70°C / -40 to 158°F
Ambient temperature (storage)	-40°C to 85°C / -40 to 185°F
Ambient humidity	95 %, non-condensing
<b>Voltage</b>	( $\lambda/\Delta$ )
120 Vac [1] Rated ( $V_{rated}$ )	69/120 Vac
Max. value ( $V_{max}$ )	86/150 Vac
Rated voltage phase - ground	150 Vac
Rated surge volt. ( $V_{surge}$ )	2.5 kV
<b>and</b> 480 Vac [4] Rated ( $V_{rated}$ )	277/480 Vac
Max. value ( $V_{max}$ )	346/600 Vac
Rated voltage phase - ground	300 Vac
Rated surge volt. ( $V_{surge}$ )	4.0 kV
Accuracy	Class 0.5
Measurable alternator windings	3p-3w, 3p-4w, 3p-4w OD
Setting range	primary 50 to 650,000 Vac
Linear measuring range	1.25 $\times V_{rated}$
Measuring frequency	50/60 Hz (40 to 85 Hz)
High Impedance Input; Resistance per path	[1] 0.498 M $\Omega$ , [4] 2.0 M $\Omega$
Max. power consumption per path	< 0.15 W
<b>Current (Isolated)</b> Rated ( $I_{rated}$ )	[1] ..1 A or [5] ..15 A
Linear measuring range	$I_{gen} = 3.0 \times I_{rated}$
	$I_{mains/ground} = 1.5 \times I_{rated}$
Setting range	1 to 32,000 A
Burden	< 0.15 VA
Rated short-time current (1 s)	[1] 50 $\times I_{rated}$ , [5] 10 $\times I_{rated}$
Accuracy	Class 0.5

<b>Power</b>	
Setting range	0.5 to 99,999.9 kW/kvar
<b>Discrete inputs</b>	isolated
Input range	12/24 Vdc (8 to 40 Vdc)
Input resistance	approx. 20 kOhms
<b>Relay outputs</b>	potential free
Contact material	AgCdO
Load (GP)	2.00 Aac@250 Vac
	2.00 Adc@24 Vdc / 0.36 Adc@125 Vdc / 0.18 Adc@250 Vdc
Pilot duty (PD)	
	1.00 Adc@24 Vdc / 0.22 Adc@125 Vdc / 0.10 Adc@250 Vdc
<b>Analog inputs (none isolated)</b>	freely scaleable
Type	0 to 10 V / 0 to 20 mA
Resolution	11 Bit
<b>Analog outputs (isolated)</b>	freely scaleable
Type	$\pm 10$ V / $\pm 20$ mA / PWM
Insulation voltage (continuously)	100 Vac
Insulation test voltage (1s)	500 Vac
Resolution	11/12 Bit (depending on analog output)
$\pm 10$ V (scaleable)	internal resistance approx. 500 Ohms
$\pm 20$ mA (scaleable)	maximum load 500 Ohms
<b>Housing</b>	Switch cabinet back mounting
Dimensions	WxHxD ..... 250 x 227 x 84 mm (9.84 x 9.00 x 3.30 in)
Connection	screw/plug terminals 2.5 mm <sup>2</sup>
Protection system	IP 20
Weight	approx. 1,900 g (4.2 lbs)
<b>Disturbance test (CE)</b>	tested according to applicable EN guidelines
<b>Listings</b>	UL, cUL, GOST-R, CSA
<b>Marine</b>	LR (Type Approval), ABS (Design Assessment)

# DIMENSIONS

## Sheet metal housing for cabinet mounting

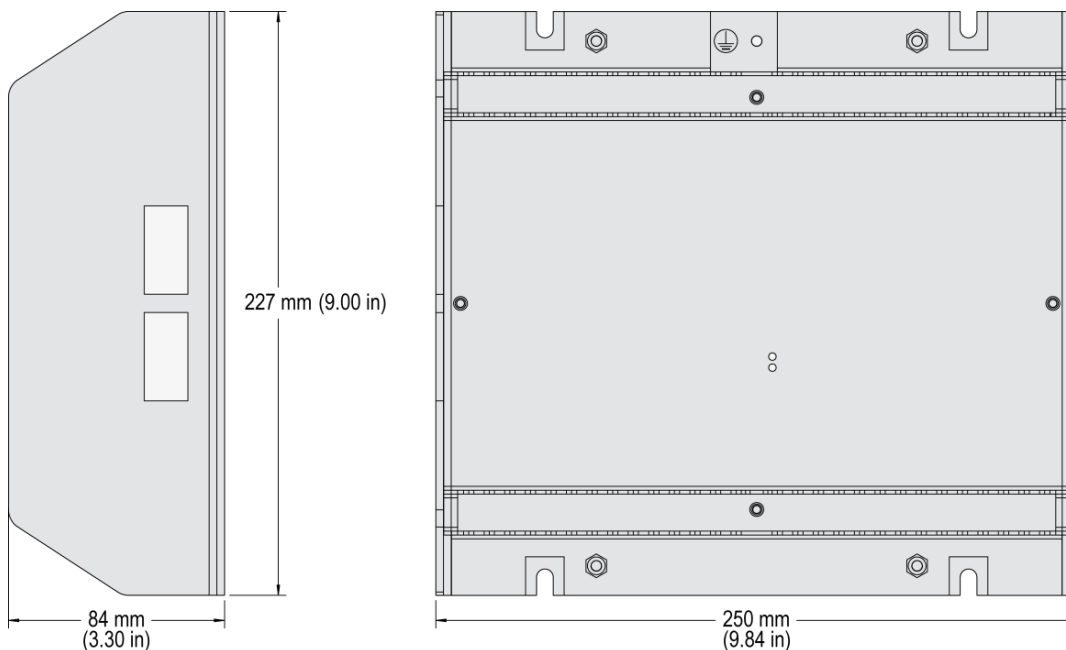

# TERMINAL DIAGRAM

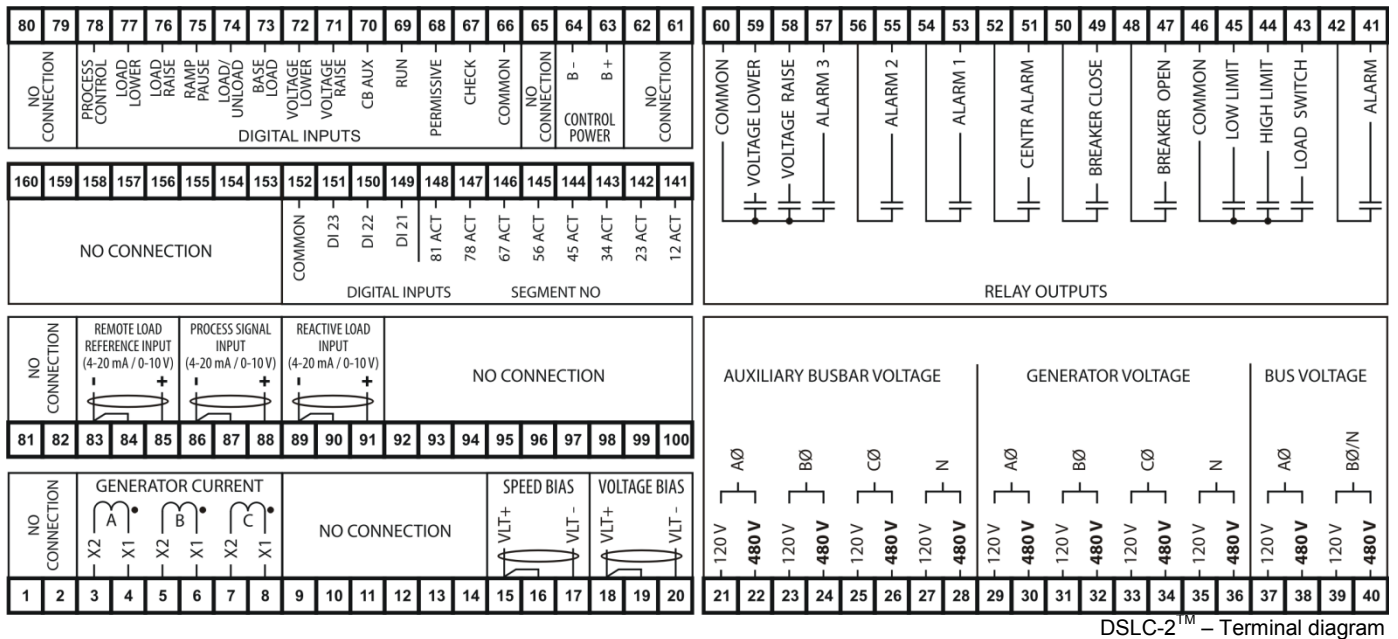

# TYPICAL CONFIGURATION

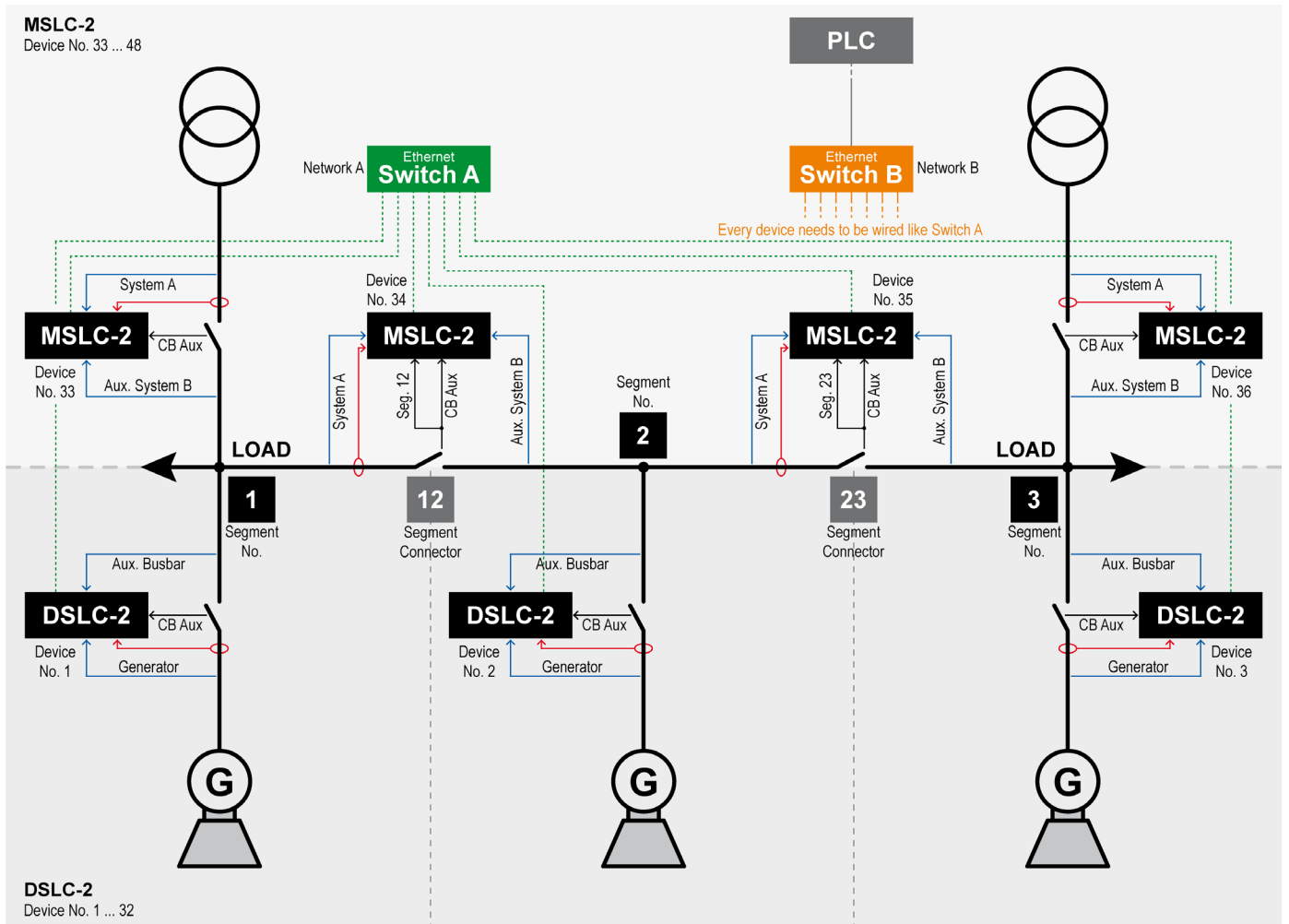

Configuration of a typical application using DSLC-2™ and MSLC-2™ devices in combination

**International**  
 Woodward  
 PO Box 1519  
 Fort Collins CO, USA  
 80522-1519  
 1000 East Drake Road  
 Fort Collins CO 80525  
 Ph: +1 (970) 482-5811  
 Fax: +1 (970) 498-3058

**Europe**  
 Woodward GmbH  
 Handwerkstrasse 29  
 70565 Stuttgart, Germany  
 Ph: +49 (0) 711 789 54-0  
 Fax: +49 (0) 711 789 54-100  
 email: stgt-info@woodward.com

**Distributors & Service**  
 Woodward has an international network of distributors and service facilities. For your nearest representative, call the Fort Collins plant or see the Worldwide Directory on our website.

[www.woodward.com/power](http://www.woodward.com/power)

For more information contact:

Subject to technical modifications.

This document is distributed for informational purposes only. It is not to be construed as creating or becoming part of any Woodward Governor Company contractual or warranty obligation unless expressly stated in a written sales contract.

We appreciate your comments about the content of our publications. Please send comments including the document number below to [stgt-doc@woodward.com](mailto:stgt-doc@woodward.com)

© Woodward

All Rights Reserved

37493B - 2011/03/Stuttgart

# TOOLKIT CONFIGURATION SOFTWARE

Woodward's ToolKit Software provides the DSLC-2™ Home Page shown below. ToolKit provides user friendly configuration, commissioning assistance, displays all operating modes, and the overview pages show what other controls the DSLC-2™ is communicating with.

**Note:** The menu tree illustrated on the left side is similar to the original DSLC™ structure.

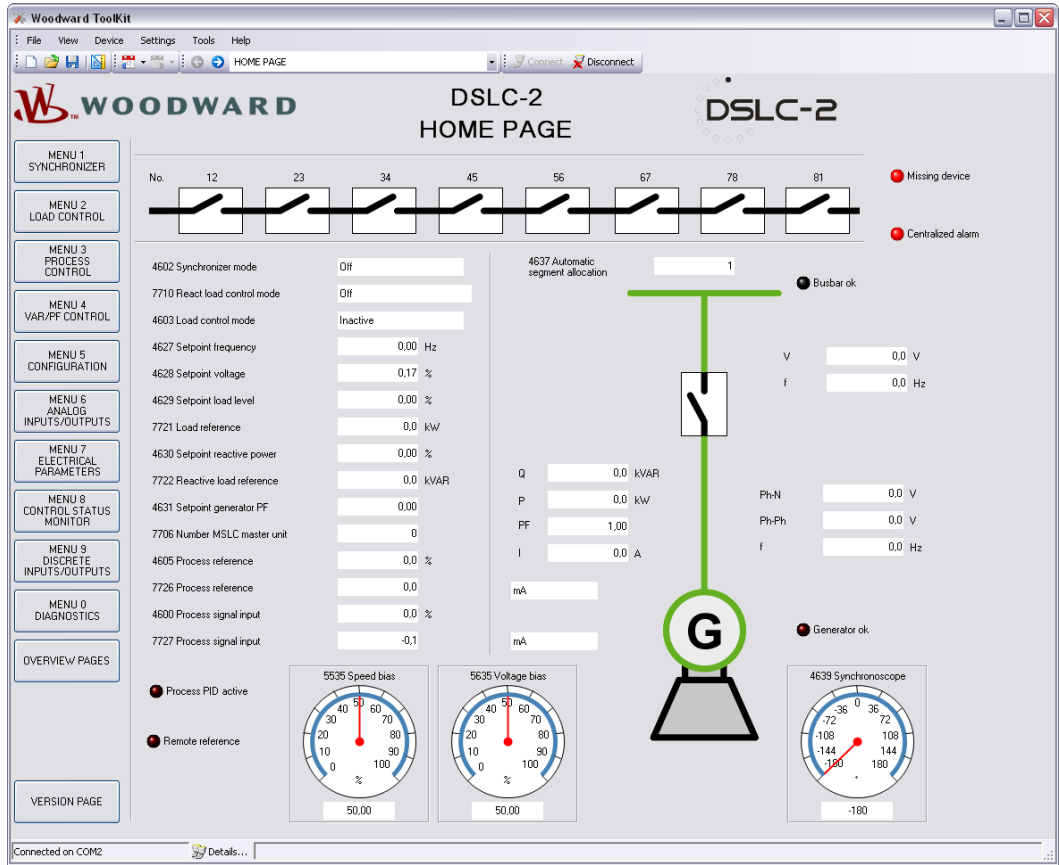

## FEATURES OVERVIEW

I/Os	DSL-2	MSLC-2
Discrete inputs	23	23
Relay outputs	12	12
Analog inputs	3	3
Analog outputs	2	-
RS-232 Interface	1	1
RS-485 Interface	1	1
Ethernet Interfaces (10/100 Mbit/s)	2	2
LED 1	CPU OK	CPU OK
LED 2	Sync Enable	Sync Enable
<b>Listings/Approvals</b>		
UL / cUL Listing	✓	✓
GOST-R & CSA	✓	✓
LR & ABS Marine	✓	✓
CE Marked	✓	✓

## PART NUMBERS

DSL-2		MSLC-2	
1A CT inputs	5A CT inputs	1A CT inputs	5A CT inputs
P/N 8440-1978	P/N 8440-1878	P/N 8440-1977	P/N 8440-1877
<b>Accessories</b>			
Spare connector kit - P/N 8923-1314			